



Morini[®] CM 162EI[®]



Technical Data

Caliber:	4.5 mm (.177)
Weight:	1020 g
Total Length:	410 mm
Total Height:	140 mm
Total Width:	50 mm
Length of Sight Line:	From 310 mm to 350 mm
Barrel Length:	240 mm
Type of Barrel:	Lothar Walther 12 dx 450 mm
Number of Riflings:	12
Functioning:	Compressed Air
Trigger:	Electronic
Path:	0 - 1.5 mm
Arrest Point:	0.1 - 0.03 mm
First Stage Weight:	300 g - 700 g
Second Stage Weight:	50 g - 300 g
Trigger:	Mounted on Micro-Roller Bearing
Voltage:	2 x 1.5 V
Battery Life:	15000 Firings ca.
Sight:	4.0 - 4.5 - 5.0 - 5.5 - 6.0 mm
Sight Slot:	Micrometrically Adjustable
Average Bullet Speed:	V ₀ = 155 m/s
Number of Shot with 200 bar:	200
Grips:	Adjustable/Fixed - Left/Right

Morini Competition Arm S.A.
Via ai Gelsi 11

CH - 6930 - Bedano - Switzerland

Tel. : +41 91 - 9352230 - Fax : +41 91 - 9352231 - www.morini.ch - morini@morini.ch

Attention:

Before using your Morini CM 162EI Compressed Air Pistol, please be sure to get absolutely well acquainted with the handling and function of the gun, guided by these instructions. Even quite a safe gun may become dangerous to you and other persons by faulty handling. Generally, hold the gun only in a way that you do not expose anyone to danger. Even an unloaded gun must generally be handled as a loaded one. Any changes to the gun, using non-original MORINI spare parts, the use of force while stripping down the gun or the presence of corrosion may very much influence safety and function of the gun. Morini, as manufacturers are, in such cases, generally discharged from any warranty. From time to time it is recommended to have the gun tested by an authorised gunsmith for safety and function.

Dear shooting friend,

You are now in possession of a Compressed Air Pistol model **MORINI CM 162EI**, manufactured in Switzerland. **Morini Competition Arm S.A.** placed in Bedano (Switzerland) produces precision target pistols, suitable for top level competitions. Modern design principles combined with the use of the best available materials, absolute precision and attention to detail in the manufacturing of all Morini products assures satisfaction in functioning and almost unlimited durability of these pistols, under normal usage. The pistol also features a very sophisticated electronic trigger mechanism, with moving parts mounted on micro-roller bearings, and a unique air pressure regulator assuring constant and uniform air release pressures. The pistol is the result of the desire to produce a high quality match air pistol combining the advantages of the precompressed air systems without the disadvantages of the usual cocking effort. Compressed air is much less affected by temperature changes and has much less recoil effects than the widely used CO₂ gas systems. Some of the worlds most experienced shooters co-operated and co-operate with Morini, helping to combine engineering design excellence, reliable functioning and accuracy with excellent balance and handling. Morini Competition Arm S.A. is also the master of producing excellent anatomical target grips for a wide range of pistols and thus the excellence in design, reliable functioning and high quality of this pistol is also complimented by the use of these well known grips, made of fine quality walnut timber.

At this point we would like to wish you good shooting.

Compressed Air Pistol Morini Model CM 162EI

This model is conceived for firing single shot of 4.5/.177 calibre. The propelling element is Air, which is found in the detachable cylinder under the barrel. Do not use CO₂ in your pistol, as it has not been conceived for this purpose the fact which may provoke inconveniences or breaks which are not considered in the guarantee. For transport purposes, the cylinder containing the air is empty and therefore you need to fill it before first use. For any damages, which are caused by non observance of the instructions, by any changing of parts, remodelling or mounting of parts which are not of **MORINI** origin, no guarantee is granted from our part.

Warranty

The compressed air pistol **MORINI CM 162EI** has a guarantee of **6 months** (not related to sealing). Within this period our obligation is to exchange, free of charge, all those parts that, due to factory defects or deterioration, are deficient. This guarantee loses its validity if the weapon has been improperly treated, inexpert repaired, or altered in any way. To receive the guarantee certificate please return us the card complete after having bought the pistol. Only then the guarantee will be valid.

1. Turning on the electronic (*Fig. 1*)

1.1 Switching on the electronic

Push the switch lever (1) up. When powered on the LED (2) shows the battery status:

Fast blinking:

Error detected

The LED flashes every 4 seconds:

Batteries OK

The LED blinks slowly:

The duty cycle between on and off shows how much the batteries are empty. If the LED is more on than off, the batteries are good, if it is more off than on it is better to change batteries

The LED force depends on the batteries voltage. If they are empty it may be more difficult to see the flashing LED. Unless more than 2 seconds are needed to generate the 20V it is still possible to shot. We strongly recommend, however, changing the batteries when the LED off period is longer then the on period.

The pistol is so ready to be loaded and for dry firing, which take place simply by pulling the trigger. The battery life is over 15'000 shots.

Error condition can occur if:

The electronic is powered on with pressed trigger:

Turn off and on again without pressing the trigger

The electronic is extracted from the trigger unit when on:

Turn off

The electronic is inserted in the trigger unit when on:

Turn off and on again

Could not reach the 20 V in 2 seconds:

The electronic is damaged or there is a short circuit on the output contacts

1.2 Introduction of the batteries

Remove the cover plate (3) situated at the base of the grip. Extract the electronic from the grip and introduce 2 batteries 1.5V Micro Type AAA paying attention to the polarity. Reinsert the electronic and put the cover plate in position again. This operation and eventually the displacement of the electronic must be done with unloaded pistol and electronic turned off.

2. Loading the pistol (*Fig. 2*)

Pull lever (1) up and introduce the pellet in the chamber and close by pushing the lever in place.

Attention: If you cannot lift the lever, it means that your pistol does not contain air or that the pressure of the air contained in the cylinder does not permit you adequate velocity and therefore the shots would result lower. In either case, fill or replace the cylinder and make sure that lever (2) does not block lever (1).

3. Trigger adjustment (*Fig. 3*)

The trigger is adjusted at the factory according to the ISSF rules in an optimal manner, but it is still modifiable by the following way:

3.1 Adjustment of trigger take-up

Turning adjustment screw (1) clockwise will shorten travel. After adjust screw (1) check trigger weight and readjust if necessary.

3.2 Adjustment of first stage travel

Turning adjustment screw (2) clockwise increases the load. The range is 300 - 700 g.

3.3 Adjustment of second stage travel

Turning adjustment screw (3) clockwise increases the load. The range is 50 - 300 g.

3.4 Adjustment of trigger position

Unlock screw (4) and move the trigger to the desired position, then lock screw (4) again.

4. Sighting adjustment (*Fig. 4*)

4.1 Vertical adjustment

To move group on target **DOWN**, turn adjustment screw (1) clockwise. One click will move hit on target by 1.5 mm.

4.2 Horizontal adjustment

To move group on target to the **RIGHT**, turn adjustment screw (2) clockwise. One click will move hit on target by 1 mm.

4.3 Adjusting the width of the rear sight notch

Turning adjustment screw (3) clockwise will widen the rear sight opening by 0.1 mm every click.

5. Sight

The pistol is supplied with a 5.0 mm wide front sight post, as standard. Other front sights with different widths (4.0 - 4.5 - 5.5 and 6.0 mm) are supplied as accessories.

6. Pellet velocity (*Fig. 5*)

Pellet velocity V_0 is set at the factory between 150 and 155 m/s (492 - 508 ft/s). It is suggested that this adjustment should not be changed if you do not have the necessary equipment. The velocity, however, is regulated by turning adjustment screw (1) clockwise.

7. Compressed Air Cylinder

It is by all means required to observe the legal dispositions and rules of the respective country

The compressed air cylinder can be unscrewed and exchanged even if not empty. While doing so a small quantity of air from the spacing chamber will escape. The filling pressure can be checked with the manometer that is built in all cylinders. The air pressure cannot exceed **200 bar / 2900 psi**. The cylinder must never be exposed to a temperature of more than **50° C (122° F)**

8. Filling the Cylinder (*Fig. 7*)

Besides of the following details, any technical regulations of your country must be observed.

Three common methods are used to fill the cylinders:

- connecting the cylinder to the adapter, supplied standard, attached to a scuba diving bottle and then opening the valve of the scuba diving cylinder for a few seconds. Close valve and unscrew cylinder from the adapter.
- connecting the cylinder to the adapter, supplied standard, attached to a hand pump. Specific instructions for the use of the hand pump will be supplied with the hand pump.
- connecting the cylinder to the adapter, supplied standard, attached to a compressor

**WARNING: DO NOT TAMPER ON CYLINDER INCLUDING THE VALVE!
DANGER! IF YOU VIOLATE THIS RULE, THE GUARANTEE EXPIRES.**

9. Empty out a Cylinder (*Fig. 6*)

To empty out a cylinder use the adapter supplied with the pistol and the air will come out. Remember to empty out all cylinders before air flights.

10. Maintenance

The pistol does not need any special maintenance, except normal inspection and service if and when necessary. No lubrication is necessary, as lubrication of the individual parts has been affected in the factory, with long lasting lubricants. It is recommended, however, to clean the pistol with a soft cloth after shooting. For cleaning the barrel bore, the use of special cleaning pellets, made for this purpose, is recommended. The barrel should be oiled internally only if it is not used for long periods. It is then to be cleaned before using the pistol again. We recommend the use of high quality Match pellets for your **MORINI** compressed air pistol.

- SUBJECT TO CHANGE -

CM 162E / CM 162EI

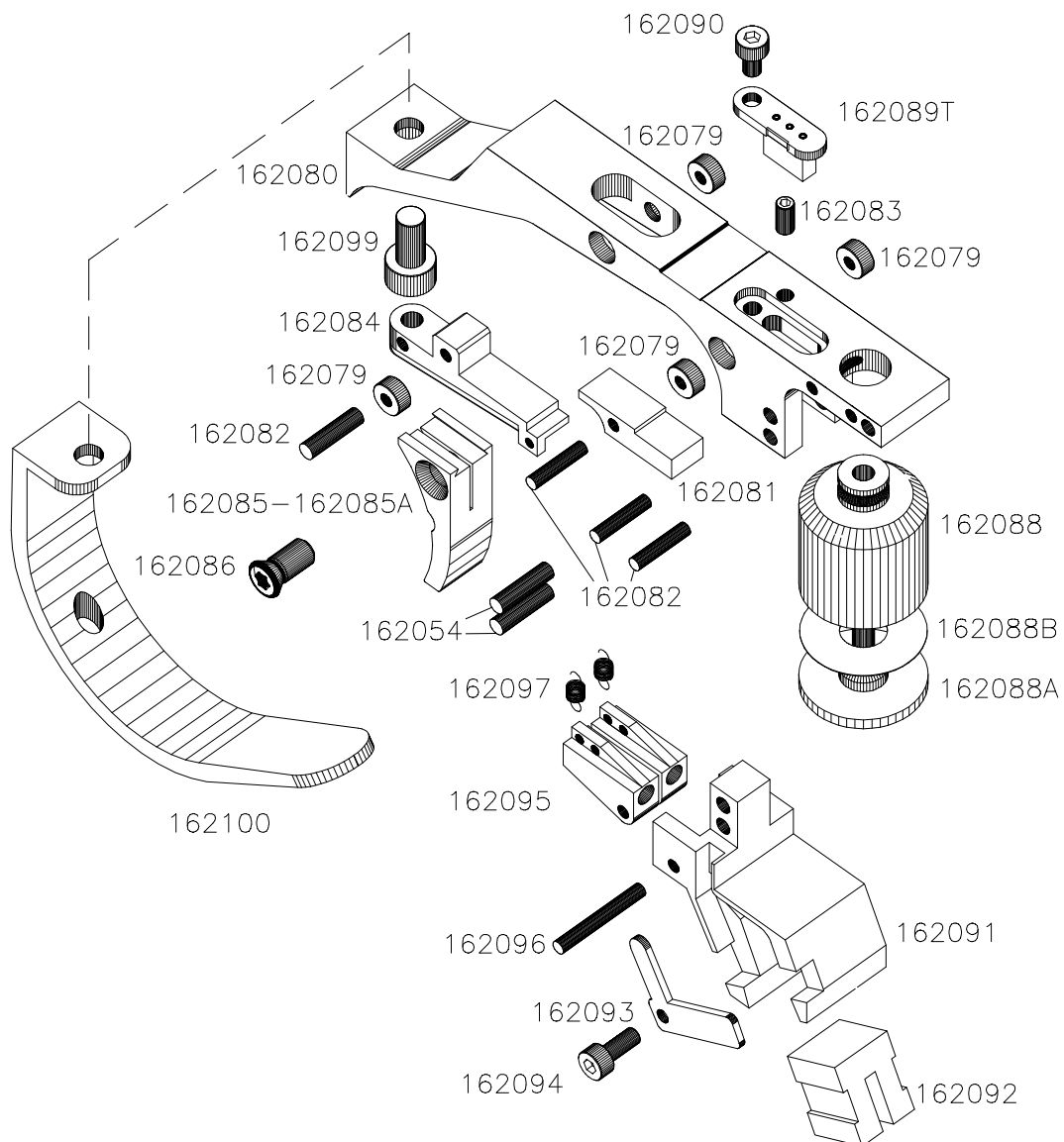

Fig. 1

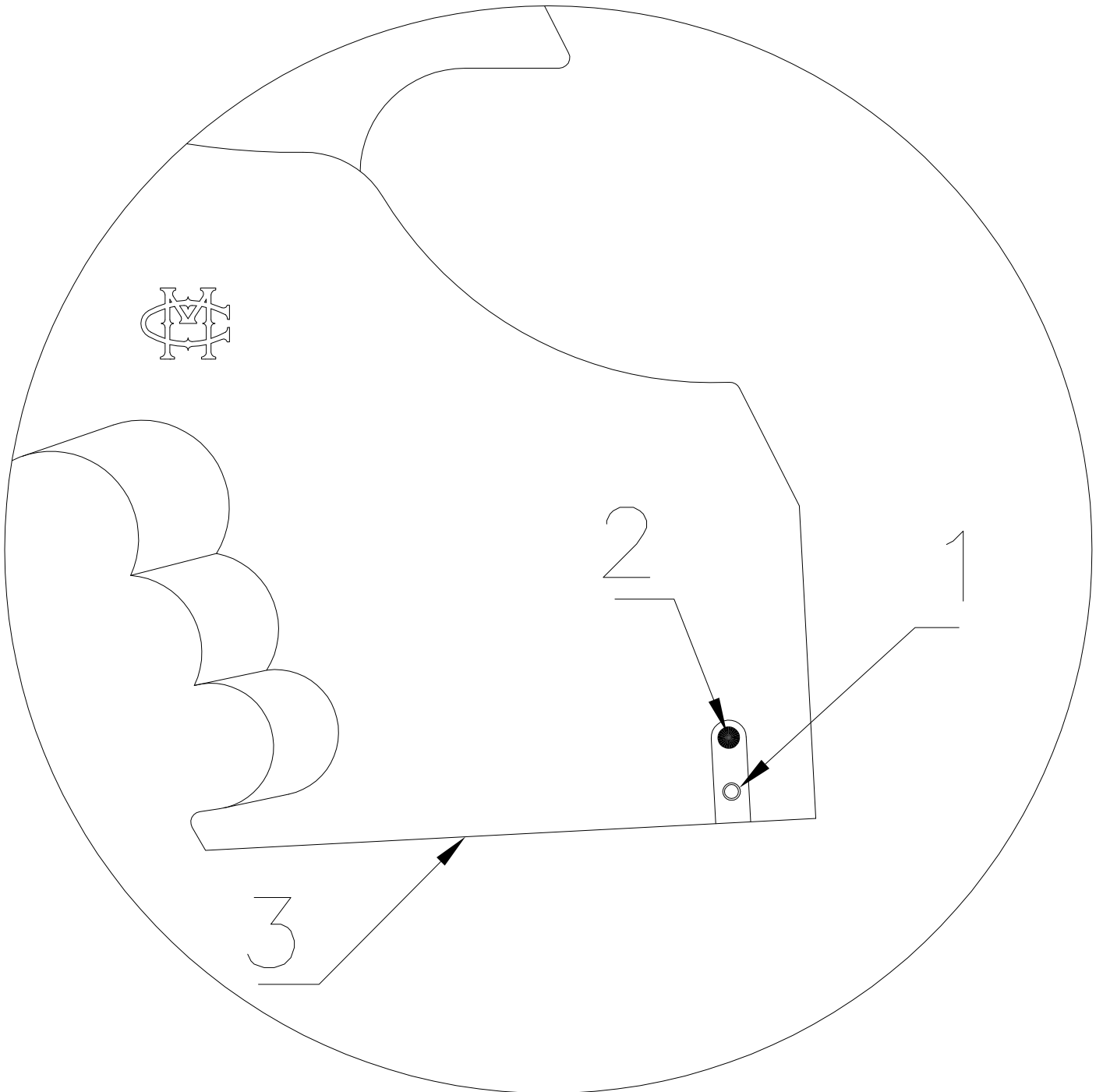

Fig. 2

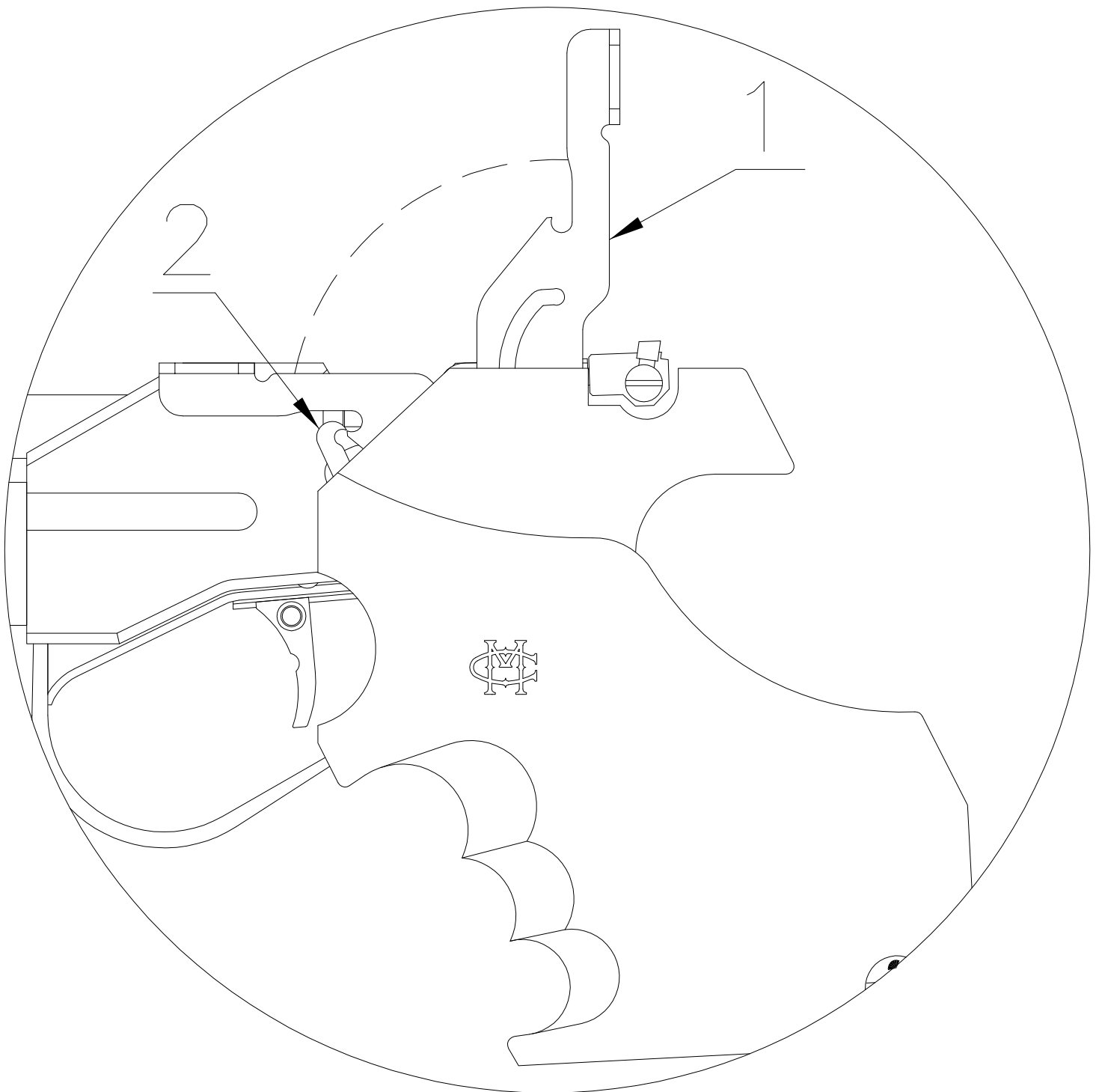

Fig. 3

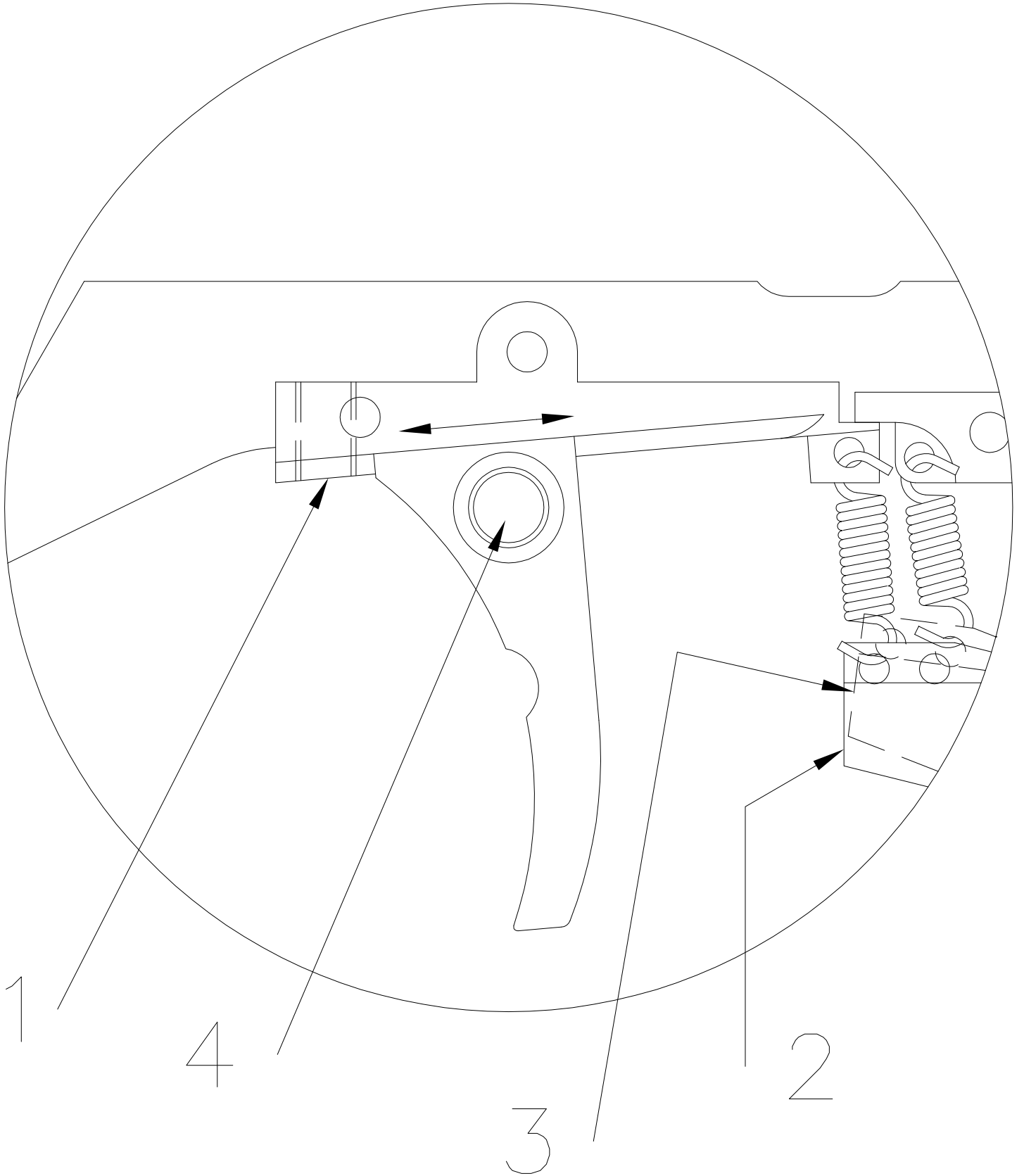

Fig. 4

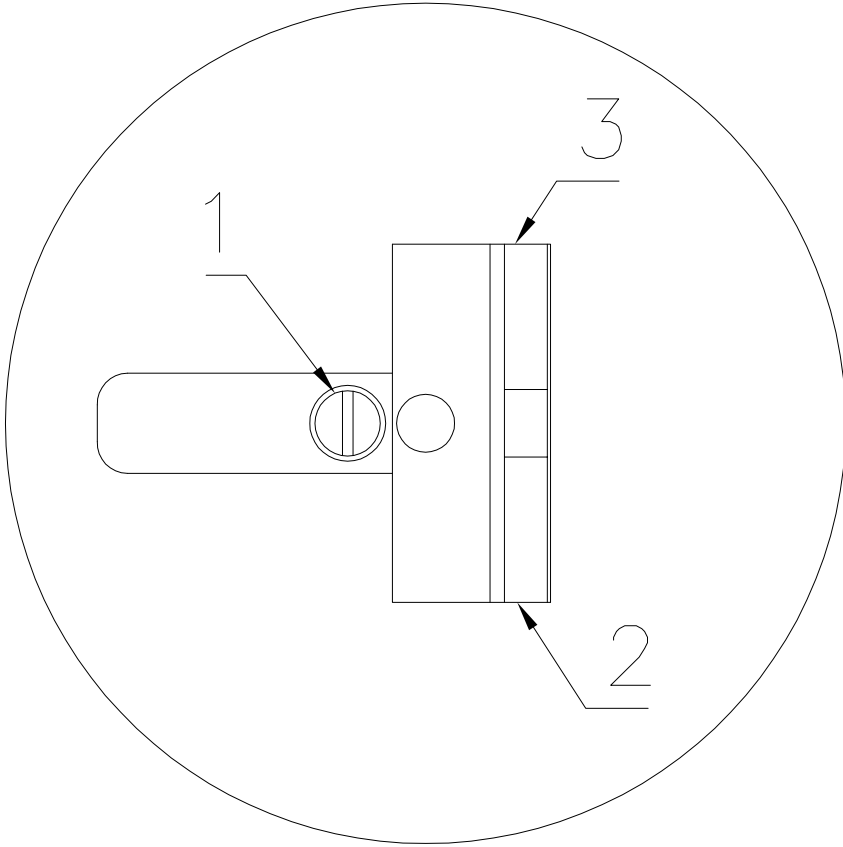

Fig. 5

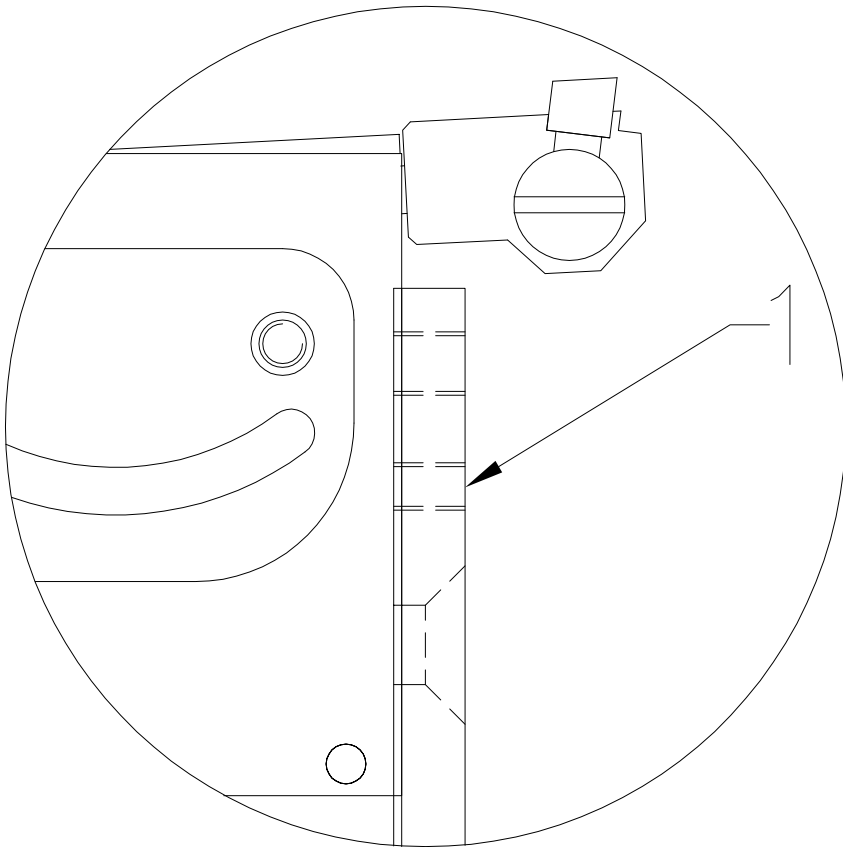

Fig. 6

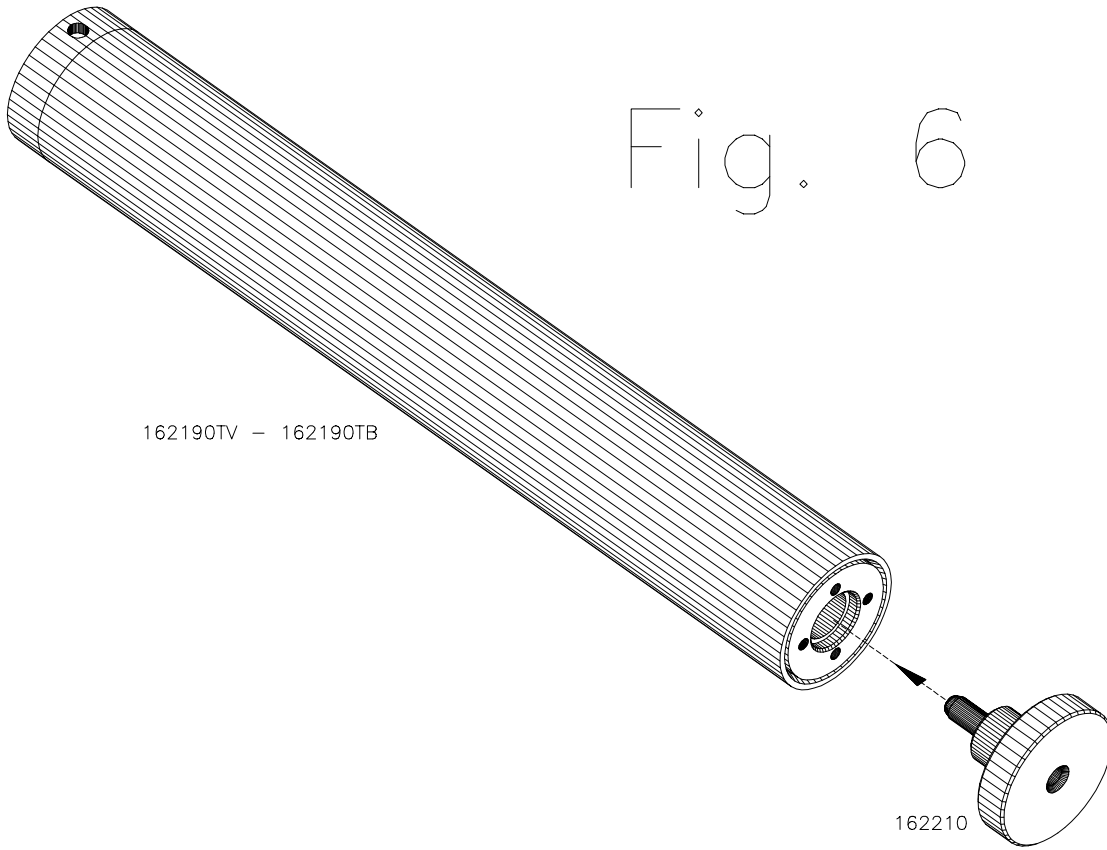

Fig. 7

